

Person-Environment Transactions During Emerging Adulthood

The Interplay Between Personality Characteristics and Social Relationships*

Cristina Sturaro¹, Jaap J.A. Denissen², Marcel A.G. van Aken², and Jens B. Asendorpf³

¹Utrecht University, The Netherlands, now VU University of Amsterdam,
²Utrecht University, The Netherlands, ³Humboldt University Berlin, Germany

Abstract. Personality (Big Five and self-esteem) effects on social relationship quality (perceived support and conflict) and vice versa were longitudinally studied during emerging adulthood. Rank-order stability correlations of personality and social relationship quality were investigated. Subsequently, the mechanisms that may underlie personality development across emerging adulthood were examined. Results from path analyses showed that social relationship quality at the age of 17 years, in particular perceived conflict, predicted change in personality from the age of 17 years to 23 years, while the reverse pattern was not found. These findings indicated that, during emerging adulthood, personality may still be in flux, and, despite its higher stability as compared to the stability of social relationship quality, may be influenced by the environment.

Keywords: person-environment transaction, mechanisms of personality development, social relationship quality, Five-Factor theory, dynamic interactionism

The issue of stability and change in personality has been one of the liveliest debates in personality psychology. Several previous studies have confirmed the presence of modest to strong consistency in personality during young adulthood (McCrae et al., 2000; Morizot & Le Blanc, 2003) while there are also many longitudinal studies showing significant changes in personality across young adulthood (Robins, Fraley, Roberts, & Trzesniewski, 2001; Shiner, Masten, & Tellegen, 2002; Stein, Newcomb, & Bentler, 1986). In their meta-analytic review of rank-order stability correlation of personality, Roberts and Del Vecchio (2000) reported moderately high levels of consistency from late adolescence to young adulthood with correlations ranging from .51 to .57 across an average test-retest period of 6.7 years (the corresponding corrected annual stability ranged from .89 to .95). Therefore, their general conclusion is that personality is reasonably stable over time, yet a certain amount of change is still possible. Accordingly, attention is now turning to the mechanisms of personality change (Roberts, Walton, & Viechtbauer, 2006b; Terracciano, McCrae, Brant, & Costa, 2005). In the present study we investigated personality development during emerging adult-

hood, taking into account both endogenic and contextualist perspectives on change. While a radically endogenic perspective assumes that personality has a strong genetic basis, a contextualist perspective poses that the environment influences personality development across the life span.

Two Perspectives on Personality Change

According to the five-factor theory (FFT) of McCrae and Costa (1999), the process by which stability and change in personality take place is hypothesized to be an intrinsic and preset process of maturation. There is some support for this position. For example, evidence from twin and adoption studies shows that individual differences are affected by genetic factors (Loehlin, 1992). In addition, McGue, Bacon and Lykken (1993) examined the personality of monozygotic and dizygotic twins over a period of 10 years, and discovered that 80% of personality stability was attributable to genetic influences. Finally, McCrae et al. (2000) have shown that cross-sectional age trends in personality development are remarkably similar across countries with very different cultural

* This paper is part of a series on "Youth Development in Europe: Transitions and Identities" that will appear in the *European Psychologist* throughout 2008. Taken together, the papers aim to make a conceptual contribution to the increasingly important area of youth development, especially within the context of an expanding Europe, by focusing on variations and changes in the transition to adulthood and emerging identities. The series will conclude with a summary by the organisers of the series, Katariina Salmela-Aro (University of Jyväskylä, Finland) and Ingrid Schoon (University of London, UK).

backgrounds and argued that this implies a primacy of endogenous, as opposed to environmental factors.

In the FFT, personality is conceptualized as a stratified system composed by core traits and surface characteristics. Core traits are conceptualized as “endogenous dispositions that follow intrinsic paths of development essentially independent of environmental influences” (McCrae et al., 2000, p. 173). These core traits are hypothesized to include the Big Five factors of personality: emotional stability (inversely called neuroticism), extraversion, agreeableness, conscientiousness, and openness/culture. Beside these basic elements, characteristic adaptations, such as self-concepts, are also part of the personality system. Within the personality system posited by the FFT, the lower level elements of personality are related to the core traits through dynamic processes, but are more susceptible to environmental influences (Asendorpf & van Aken, 2003; McCrae & Costa, 1999; McCrae et al., 2000). Because one of the aims of the present study was to examine the effects of contextual influence on personality change, it seemed important to uphold the distinction between core traits and surface traits (Asendorpf & van Aken, 2003) in order to differentiate between more stable and more flexible layers of personality, which may differ in their receptiveness to environmental influences.

In contrast to the biological position taken by the FFT, scholars adopting a more contextualistic perspective claim that personality traits are multiply determined and that the environment plays a considerable role in promoting change or maintaining stability in personality. Specifically, in *dynamic interactionism*, individuals are conceived to develop through a dynamic, continuous, and reciprocal process of transaction with their environment (Caspi, 1998; Caspi & Bem, 1990; Magnusson, 1990, 1999). Following this perspective, personality may undergo an enduring and complex process of change due to environmental influences and the continuous interaction of the individual with external factors (Srivastava, John, Gosling, & Potter, 2003). Likewise, it is expected that both personality and environment may develop across time reciprocal causal effects on one another. Furthermore, researchers have hypothesized that personality stability is the product of being surrounded by a stable environment (e.g., Moss & Susman, 1980). This *parallel continuities* hypothesis states that personality will show higher stability when individuals live in a more stable environment, whereas it will be more likely to change when individuals are embedded in a less stable environment. Accordingly, periods of life characterized by many changes in an individual's environment may be associated with changes in personality (Scollon & Diener, 2006).

Personality Change in Emerging Adulthood

Emerging adulthood is a distinct period of the life course (from the age of 18 years to 25 years) characterized by considerable psychological and environmental changes (Arnett, 2000). The transition from adolescence into young adulthood

is a time in which individuals have left the dependency that characterizes childhood and adolescence and, relatively independently, begin to experiment with social and normative roles expected for the adults in search for their place in society (Arnett, 2000). During emerging adulthood, individuals pass through various demographical transitions that mark the entry in adulthood status, such as completing school, obtaining employment and gaining financial independence, leaving the parental house, getting married, and starting a family (Arnett, 2000). The transitional nature of emerging adulthood is also distinguished by identifiable psychological features that characterize individuals when confronted with the task of forming a secure identity, and which will assist them in the choice and maintenance of the commitments typical of adulthood-related roles (Arnett, 2004). Identity formation is a process that involves psychological aspects such as the exploration of commitments, ego strength, self-efficacy, cognitive flexibility and complexity, self-monitoring, critical thinking abilities, moral reasoning abilities, and other features which provide the individual the ability to understand and negotiate the various social, occupational, and personal challenges (Côté, 1996).

Due to the transitional character of this period, emerging adulthood is a time during which personality may be particularly susceptible to environmental influences, and thus, changes are more likely to appear. Indeed, from their meta-analysis of mean-level personality change, Roberts, Walton, and Viechtbauer (2006a) concluded that “the most noteworthy finding was that personality traits changed more often in young adulthood than any other period of the life course, including adolescence” (p. 14).

What causes these personality changes in emerging adulthood? According to Roberts, Wood and Smith's (2005) social investment theory, investing in age-graded social roles, may be associated with increasing personality maturity. According to the so-called Socioanalytic perspective, “maturity is related to certain performance capacities—namely, the ability to form lasting relationships and to achieve one's career goals” (Hogan & Roberts, 2004, p. 1). As stated by Hogan and Roberts (2004), this ability is fostered by high levels of emotional stability, conscientiousness, and agreeableness. Therefore, committing to adult roles or having expectations regarding the assumption of these roles may increase individuals' social dominance, agreeableness, and conscientiousness, and decrease the level of neuroticism. Supporting this position, a meta-analysis of normative (mean-level) change indicated that personality traits show a clear pattern of maturation across the life course, with increasing levels of emotional stability, conscientiousness, and agreeableness (B.W. Roberts, Walton, & Viechtbauer, 2006a).

It is largely recognized that interpersonal relationships are central to the lives of individuals and to their personality development. In particular, social relationships have been found to have an effect on surface characteristics of personality, for instance, on self-esteem and psychological well-being (Roberts & Bengtson, 1993). On the other hand,

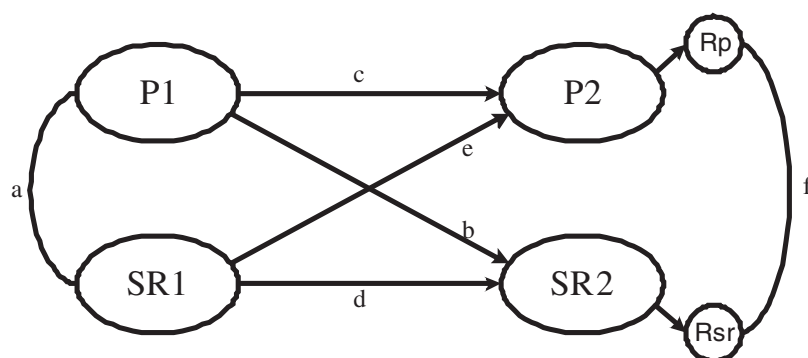

Figure 1. Associations between personality and social relationships between age 17 and 23. Cross-lagged paths between personality (P1, P2) and social relationship (SR1, SR2), and correlated change of personality and environment at Time 2 (Rp, Rsr), controlling for both variables' long-term stability. Path analysis labels are indicated by the letters a, b, c, d, e, and f.

personality has also been found to have an effect on individuals' perceived support (Asendorpf & van Aken, 2003), quality of social relationships (Asendorpf & Wilpers, 1998; Neyer & Asendorpf, 2001), and romantic relationships (Robins, Caspi, & Moffitt, 2002). Parent-child relationships are especially significant, because these relationships begin early in life and continue to be important across a large part of the life course (Hartup & Laursen, 1999). Across adolescence, time spent with peers increases substantially (Rubin, Bukowski, & Parker, 1998) and peers begin to play a progressively more relevant role in adolescents' life (Helsen, Vollebergh, & Meeus, 2000) alongside the enduring relevant role of parents. Accordingly, we wanted to examine the development of personality in relation with both parental and best friend relationship quality. Given the relatively high instability of romantic relationships during emerging adulthood, it was decided to exclude relationships with a romantic nature from the study. Moreover, we decided to restrict the field of interest on peer relationships to same sex best friend to avoid the possible risk of opposite sex friendships developing into a romantic relationship. It is our expectation that meaningful associations exist between personality and relationship quality with parents and peers.

The Present Study

The leading aim of the present study is to examine the development of personality throughout emerging adulthood, and how personality characteristics (core as well as surface) are related over time to perceived quality of social relationships (social support and conflict) with parents and best friend. More specifically, we have examined four aspects of personality development. First, we investigated rank-order stability correlations from the age of 17 years to the age of 23 years in Big Five traits and self-esteem and compared them to the stability of social relationships quality. Second, we examined the predictive power of personality at the age of 17 years on changes in quality of relationships with parents and best friend between age 17 and 23. Third, we investigated whether social support and conflict perceived at the age of 17 years can predict change in

personality between the age of 17 years and 23 years. Finally, we explored whether changes in the environment (perceived social support and conflict) between the age of 17 years and 23 years are correlated with changes in personality characteristics across the same period of time.

The current paper addresses the following hypotheses:

- *Hypothesis 1.* Following the FFT and dynamic interactionism paradigms, we expect personality at the age of 17 years can predict change in relationship quality between the age of 17 years and 23 years (see path b in Figure 1).
- *Hypothesis 2.* Following the dynamic interactionism paradigm, we expect that relationship quality at the age of 17 years predicts change in personality between age of 17 years and 23 years (see path e in Figure 1). According to the distinction between the multiple dimensions of personality, we expect relationship quality to have an influence on surface characteristics between the age of 17 years and 23 years, but not on the Big Five traits.
- *Hypothesis 3.* Following the parallel continuity hypothesis, we expect changes in perceived social support and conflict between the age of 17 years and the age of 23 years to be correlated with changes in personality across the same period of time (see path f in Figure 1).

Method

Participants

The target sample for the present study consisted of 154 participants that were assessed at the ages of 17 and 23 years. These participants were part of the Munich Longitudinal Study on the Genesis of Individual Competencies (LOGIC; Weinert & Schneider, 1999). The LOGIC sample originally consisted of 230 children who started to attend 20 preschools in the Munich area in the fall of 1984 when they were 3–4 years old and whose first language was German. This initial sample of 230 children (119 males) was rather unbiased because the schools were selected from a broad spectrum of neighborhoods, and more than 90% of the parents who were asked for permission gave their con-

sent for their child's participation. Repeated measurements were assessed between Year 3 and Year 12. The socio-economic status (SES) of the original sample, defined by father's occupational status, was representative of the population and was divided as follows: 28% having low SES, 63% having average SES, and 9% having high SES. After 9 years the comparison between the drop out sample and the remaining sample did not show any significant difference regarding both sex and SES (LOGIC; Weinert & Schneider, 1999). After the age of 12 years, the sample was reassessed at the age of 17 years and the age of 23 years. At the age of 17 years, the sample included 174 participants (93 males), which amounts to 76% of the original sample. At the age of 23 years, 154 participants were still in the sample (81 males; retention rate of 89% compared to the age of 17 years).

Age 17 Measures

Big Five

Participants provided ratings on extraversion, emotional stability, agreeableness, conscientiousness, and culture. Big Five factors were assessed by bipolar adjective pairs that were obtained from a study by Ostendorf (1990). Sample items include *Agreeableness*: Vengeful vs. forgiving; *Extraversion*: Unsociable vs. outgoing; *Emotional Stability*: Irritable vs. calm; *Conscientiousness*: Lazy vs. diligent; and *Culture*: Uneducated vs. knowledgeable. Reliabilities for the Big Five scales ranged from .75 to .88, mean $\alpha = .82$.

Self-Esteem

Participants provided ratings on self-esteem using the short six-item General Self-Esteem scale of the Self-Description Questionnaire III (SDQ III; Marsh & O'Neill, 1984). This scale showed a satisfactory internal consistency ($\alpha = .79$).

Quality of Social Relationships

Participants provided ratings of perceived support from mother, father, and same-sex best friend using a German adaptation of the Network of Relationships Inventory (NRI; Furman & Buhrmeister, 1985). This instrument assesses the amount of instrumental help, intimacy, esteem enhancement, and reliability in specific relationships. For the current analyses, these facets were averaged to create a composite scale of perceived support. Participants also provided ratings on conflict with mother, father, and best friend of the same sex using a subscale of the Network of Relationship Inventory. Internal consistency of both scales was satisfactory ($\alpha s > .70$).

Age 23 Measures

Big Five

Participants provided ratings on Big Five factors using a German version of the NEO-Five Factor Inventory (NEO-FFI, framed in the third person; Borkenau & Ostendorf, 1993), which consists of 60 items (response scale 1–5). Reliabilities of the Big Five scales ranged from .64 (openness) to .91 (conscientiousness), mean $\alpha = .78$. Below are reported some examples of the items for each of the NEO-FFI's five factors: *Agreeableness*: "I believe that most people will take advantage of you if let them" (reversed), "I generally try to be thoughtful and considerate"; *Extraversion*: "I like to have a lot of people around me," "I usually prefer to do things alone" (reversed); *Emotional Stability*: "I am not a worrier," "I often feel tense and jittery"; *Conscientiousness*: "I am efficient and effective at my work," "I waste a lot of time before settling down to work" (reversed); and *Openness*: "I often enjoy playing with theories and abstract ideas," "I have a lot of intellectual curiosity."

Because of the change of instrument to assess personality between the two measurements, we decided to analyze the applicability of two heterotypic measures of personality. Both instruments were applied in a sample of 641 German college students, aged between the age of 16 years and 23 years ($M = 20.64$), with 75.5% of the sample being women (we kindly thank Fritz Ostendorf for generously providing these data). Below the raw correlations between the adjective instrument and the NEO-FFI are reported, followed in the brackets by the correlations corrected for attenuation. Agreeableness $r = .68$, (.87); Extraversion $r = .81$, (.92); Emotional Stability/Neuroticism $r = .79$, (.89); Conscientiousness $r = .77$, (.87); and Openness/Culture $r = .38$ (.52). Apart from the fifth factor, the corrected correlations provide evidence of excellent convergent validity.

Self-Esteem

Participants provided ratings on self-esteem using the six-item General Self-Esteem Scale of the SDQ-III (Marsh & O'Neill, 1984). This scale showed a satisfactory internal consistency ($\alpha = .79$).

Quality of Social Relationships

Social relationships were assessed with an ego-centered social network questionnaire (Asendorpf & Wilpers, 1998; Neyer & Asendorpf, 2001), which differed from the NRI used at age 17 years. This instrument requires participants to list people they had interacted with during the past month. After listing these contact persons, they rated each individual relationship on five Likert scales: Personal closeness, exchange of personal thoughts and feelings, felt acceptance, conflict, and emotional support (response

Table 1. Intercorrelation of the variables at ages 17 and 23, and their 6-year rank-order stability correlation

Variable	Personality						Social relationship quality					
	Ext	Emo	Agr	Con	Ope/Cul	Self-esteem	Mother conflict	Mother support	Father conflict	Father support	Best friend conflict	Best friend support
Extraversion	.45	.49	.22	.26	-.03	.53	.00	-.08	.03	.18	.03	.23
Emotional Stability	.45	.35	.10	.34	-.10	.62	-.02	-.14	-.32	.16	.07	.00
Agreeableness	.26	.21	.56	.12	.05	.14	-.13	.11	-.14	.12	.11	-.19
Conscientiousness	.05	.07	.13	.46	-.21	.29	-.23	.19	-.12	.23	.14	-.07
Openness/Culture	.20	.30	.04	.23	.22	.04	.01	-.01	-.01	-.03	-.02	-.08
Self-esteem	.32	.58	.19	.14	.35	.39	-.10	.08	-.29	.28	-.17	.15
Mother conflict	.08	.08	-.18	-.01	.03	-.03	.24	-.41	.41	-.26	.18	-.06
Mother support	.16	.06	.25	.16	.06	.15	-.57	.22	-.21	.69	-.26	.54
Father conflict	.05	-.13	-.23	.00	-.16	-.21	.42	-.23	.27	-.41	.34	-.08
Father support	.05	.12	.18	.22	.07	.30	-.34	.48	-.31	.30	-.27	.44
Best friend conflict	-.09	-.15	-.30	-.08	.08	-.05	.23	-.13	.20	-.13	.17	-.22
Best friend support	.25	.04	.18	.17	-.04	.07	-.05	.23	.05	.02	-.18	.14

Note. Big Five and self-esteem $N = 123$; Mothers quality of relationship $N = 141$; Fathers quality of relationship $N = 115$; Best friend quality of relationship $N = 119$. Intercorrelations at age 17 are below the diagonal, intercorrelations at age 23 are above the diagonal; on the diagonal are the rank-order stabilities between age 17 and age 23 (in *italics*). Significant correlations ($p < .05$) in **bold**.

scale 1–5). Exploratory factor analysis of these ratings using Varimax rotation resulted in a clear two-factor solution explaining 73% of the variance. Closeness, exchange, acceptance, and support all loaded very highly on the first factor (primary loadings between .72 and .85, secondary loadings between $-.42$ and .11), whereas conflict dominated the second factor (loading = .96). The items of the first factor were averaged to form a composite index of perceived support ($\alpha = .82$), whereas the conflict rating was retained as a separate variable, perceived conflict. For the present study, ratings of relationships with mothers, fathers, and same-sex best friend will be used. It should be noted the best friend of at least some participants may have changed between the age of 17 years and 23 years, which is an inevitable result of fluctuations in social networks but potentially attenuates the test-retest stability of this variable.

Analytic Strategy

Stability of personality traits and quality of relationships were assessed by obtaining Pearson correlations between the age of 17 years and the age of 23 years. To test the effects of personality on social relationship quality change, and the effects of social relationship quality on personality change (see paths b and e in Figure 1, respectively) and the correlated change between personality and social relationship quality (see path f in Figure 1), we performed path analysis using AMOS 5.0 software for Structural Equation Modeling. Path analysis is a particularly useful method to analyze the effect of personality on social relationship quality controlling for antecedent effects of personality on relationship quality, (i.e., the correlations between these two dimension at Time 1; path a in

Figure 1), as well as for the temporal stability of the dependent variable (paths c and d in Figure 1). We repeated a total of 36 models, each with a different combination of the six variables of personality (Big Five and self-esteem), and of the six variables on social relationship quality (perceived conflict and perceived support with mother, father and best friend). Because these models were completely saturated, fit indices were perfect.

Results

Intercorrelation Between Personality and Social Relationships at Age 17 and Age 23

In Table 1, the intercorrelations of the main variables are presented. At age 17, the trait that showed the highest number of significant correlations with social relationship quality was agreeableness, which was negatively associated with conflicts with mother, father, and best friend. Among the other Big Five traits, extraversion was significantly positively correlated with perceived support from best friend, and conscientiousness was positively correlated with perceived support from father. Six years later, Conscientiousness was negatively correlated with conflict with mother, and positively correlated with perceived support from mother and with perceived support from father. Emotional stability was negatively correlated with conflict with father, extraversion was positively correlated with conflict with best friend, and agreeableness was negatively correlated with perceived support from best friend.

Table 2. Cross-lagged path coefficients indicating the effect of personality on changes in social relationship quality

	Mother		Support		Father		Support		Best Friend		Support		Mean	
	Conflict				Conflict				Conflict				Personality	
	β	S.E.	β	S.E.	β	S.E.	β	S.E.	β	S.E.	β	S.E.	β	S.E.
Extraversion	-.03	.09	-.12	.09	.02	.09	.06	.09	.13	.09	.11	.10	-.01	.04
Agreeableness	-.08	.09	.05	.09	-.06	.10	.13	.09	.06	.10	.10	.09	.06	.04
Emotional Stability	-.08	.09	-.08	.09	-.13	.09	.05	.09	.08	.09	.07	.09	.03	.04
Conscientiousness	-.14	.09	.05	.09	-.04	.09	.13	.09	.02	.09	.04	.09	.07	.04
Openness/Culture	.02	.09	-.03	.09	.06	.10	-.01	.09	-.02	.09	.11	.09	.00	.04
Self-esteem	-.08	.09	-.15	.09	-.09	.10	-.04	.10	-.04	.09	.04	.09	.01	.04
Mean Social Relationship Quality	.07	.04	-.05	.04	.04	.04	.05	.04	-.04	.04	.08	.04	.03	.02

Note. * $p < .05$, ** $p < .01$. In the reported means of β coefficients Conflict with mother, father, and best friend have to be considered as lack of conflict because β values have been recoded into positive values. Applying a Bonferroni correction (given 36 statistical tests), the p value for each test becomes .0014, requiring $r \geq .26$ (none of the above coefficients passed this threshold).

Stability of Personality and Social Relationships Quality

Rank-order stabilities for the Big Five, self-esteem and social relationships quality are also presented in Table 1. Big Five factors showed moderate to high stability from age 17 to age 23 (mean $r = .41$). Self-esteem also showed a moderate size correlation from age 17 to age 23 ($r = .39$). The moderate sizes of these stability correlations suggest that personality is somewhat stable between age 17 and age 23, yet there is also considerable room for change.

Quality of relationship with both mothers and fathers showed a small to moderate stability from age 17 to age 23, with correlations ranging from .22 for perceived support from mother to .30 for perceived support from father. No significant correlation was found for the quality of relationship with best friend from 17 years to 23 years. Overall, the small sizes of these correlations (mean $r = .22$) suggest that social relationships quality is subject to changes during emerging adulthood. Steiger's (1980) test for mean differences between same sample correlations showed that personality traits (Big Five and self-esteem) were significantly more stable than social relationships quality, $z = 1.62$, $p = .05$, whereas the mean of correlation of the Big Five was not significantly different from self-esteem, $z = 0.22$, $p = .41$.

Personality Effects on Social Relationship Quality Change

In the first hypothesis we expected personality to influence changes in social relationship quality. The betas, with their corresponding standardized errors, are reported in Table 2 and display the path coefficients for the direct path leading from each Big Five and self-esteem at Time 1 to the social relationship quality variables at Time 2 (see path b in Figure 1). In the last column and in the last row of Table 2, we

report the mean (after Fisher r -to- z transformation and back-transformation) betas of personality characteristics as predictors (range from $\bar{\beta} = -.01$, $SE = .04$ to $\bar{\beta} = .07$, $SE = .04$) and of social relationship quality as dependent variables (range from $\bar{\beta} = -.05$, $SE = .04$ to $\bar{\beta} = .08$, $SE = .04$), respectively. In addition, the overall mean β indicating the impact of personality on social relationship quality ($\bar{\beta} = .03$, $SE = .02$) is reported in Table 2.

Unexpectedly, none of the 36 regressions resulted in a significant path coefficient. This lack of results suggests that personality does not have an effect on changes in social relationship quality, which is inconsistent with Hypothesis 1.

Social Relationship Quality Effect on Personality Change

In the second hypothesis we stated that social relationship quality affects changes in personality across emerging adulthood. The betas and their corresponding standardized errors for social relationship quality are presented in Table 3 and refer to the path coefficients for the direct path leading from each social relationship quality variable at Time 1 to personality at Time 2 (see path e in Figure 1). We found 8 out of 36 significant results (i.e., 22%), which is higher than the number of results expected by chance ($\chi^2 = 4.54$, $p < .05$). As can be seen in Table 3, perceived conflict with father was the strongest factor related to personality change, negatively affecting emotional stability, conscientiousness, and self-esteem. Conflict with mother had an effect on changes in emotional stability and self-esteem. Conflict with best friend had an effect on extraversion and on self-esteem, while perceived support from best friend was positively related to changes in extraversion. Applying a Bonferroni correction, the required p value for each test becomes .0014. Two associations survived this criterion: The positive path between support from best friend and

Table 3. Cross-lagged path coefficients indicating the effect of social relationship quality on changes in personality

	Ext		Agr		Emo		Con		Ope/Cul		Self-esteem		Mean social relationship quality	
	β	S.E.	β	S.E.	β	S.E.	β	S.E.	β	S.E.	β	S.E.	β	S.E.
Mother conflict	-.09	.08	.03	.08	-.15*	.08	-.13	.07	.06	.08	-.19*	.08	.08	.03
Mother support	.06	.08	.04	.08	.02	.08	.09	.07	-.07	.08	.14	.08	.05	.03
Father conflict	-.12	.08	-.09	.08	-.27**	.08	-.21**	.07	-.08	.09	-.23**	.08	.17	.03
Father support	.05	.08	.01	.08	.09	.08	.00	.08	-.01	.09	.10	.09	.04	.03
Best friend conflict	-.18*	.08	-.09	.09	-.10	.08	-.01	.08	.02	.09	-.18*	.08	.09	.03
Best friend support	.29**	.08	.07	.09	.04	.08	.10	.08	.03	.09	.08	.08	.10	.03
Mean personality	.13	.03	.04	.03	.11	.03	.09	.03	-.01	.03	.15	.03	.09	.01

Note. * $p < .05$, ** $p < .01$. In the reported means of β coefficients conflict with mother, father, and best friend have to be considered as lack of conflict because β values have been recoded into positive values. Applying a Bonferroni correction (given 36 statistical tests), the p value for each test becomes .0014, requiring $r \geq .26$ (corresponding values are displayed in **bold**).

Table 4. Correlated change between personality and social relationship quality

	Mother		Father		Best friend	
	Conflict	Support	Conflict	Support	Conflict	Support
	r	r	r	r	r	r
Extraversion	.04	-.06	.06	.11	.01	.17*
Agreeableness	-.11	.08	-.11	.05	-.19*	.07
Emotional stability	.05	-.13	-.23*	.13	-.02	.04
Conscientiousness	-.16	.16	-.07	.11	-.09	.12
Openness/culture	-.01	.01	.02	-.05	-.10	-.04
Self-esteem	-.02	.10	-.19*	.23*	-.13	.14

Note. * $p < .05$. Applying a Bonferroni correction (given 36 statistical tests), the p value for each test becomes .0014, requiring $r \geq .26$ (corresponding values are displayed in **bold**).

extraversion, and the negative path between conflict with father and emotional stability.

The mean betas of social relationship quality as predictors (range from $\bar{\beta} = .04$, $SE = .03$ to $\bar{\beta} = .17$, $SE = .03$) and personality as dependent variable (range from $\bar{\beta} = -.01$, $SE = .03$ to $\bar{\beta} = .15$, $SE = .03$) are presented in the last column and in the last row of Table 3, respectively. The overall mean β related to the paths from social relationship quality to personality ($\bar{\beta} = .09$, $SE = .01$) was also calculated and reported in Table 3.

Table 3 shows that conflict with father stands out as the strongest factor influencing personality change ($\bar{\beta} = .17$, $SE = .03$), which is also demonstrated by the fact that the corresponding confidence interval ($.14 < \bar{\beta} < .20$) did not overlap with that of the immediate second highest mean β of perceived support ($.07 < \bar{\beta} < .13$). In a descending order, according to their power of prediction, are perceived conflict with best friend ($\bar{\beta} = .09$, $SE = .03$) and conflict with mother ($\bar{\beta} = .08$, $SE = .03$). Regarding the different personality characteristics, results showed that the surface trait of self-esteem is most likely to be influenced by social relationship quality ($\bar{\beta} = .15$, $SE = .03$), followed in a descending order by extraversion ($\bar{\beta} = .13$, $SE = .03$), emotional stability ($\bar{\beta} = .11$, $SE = .03$), and conscientiousness ($\bar{\beta} = .09$, $SE = .03$). All in all, these results suggest a clear dis-

inction between positive and negative dimensions of relationship quality, with conflict being more influential than perceived support in affecting personality change. Although the size of these associations may not seem large, two things should be noted. First, personality was found to be moderately stable between ages 17 and 23 years, so the fact that there was still some change left that could be predicted by social relationships is quite impressive. Second, half of the associations between social relationships and personality change ranged between .20 and .30, which is the typical strength of associations between personality and external criteria (Mischel, 1996).

In sum, social relationship quality has an influence on personality change over time, with perceived conflict with father being the strongest predictor of personality change.

Correlated Change Between Personality and Social Relationship Quality

The third and last hypothesis referred to the correlated change of personality and social relationship quality over time. In Table 4 coefficients indicating the results from path analysis on correlated change are presented. Change in conflict with father was negatively correlated with changes

in emotional stability and with changes in self-esteem, while changes in perceived support from father were positively correlated with changes in self-esteem. Changes in perceived conflict with best friend were negatively correlated with changes in agreeableness, while changes in perceived support from best friend were positively related with changes in extraversion. However, the number of these significant results is lower than expected by chance, $\chi^2 = 1.66$, $p \leq .20$.

Discussion

The main aim of the present study was to analyze the development of personality in transaction with social relationship quality during emerging adulthood. In order to do so, we first examined the rank-order stability correlation of personality characteristics across a 6-year observation interval. The stability of social relationship quality was also examined and expected to be lower than the stability of personality characteristics. Secondly, we explored which kind of mechanism may underlie personality development across emerging adulthood. The endogenous view of personality development posited by the Five-Factor theory (FFT) was compared to a more contextualistic position represented by the dynamic interactionism paradigm. Correlated change between personality and social relationship quality was also examined to investigate the parallel continuities hypothesis.

Results confirmed that the Big Five are moderately stable over time, with a mean rank-order stability correlation of .41, which is only slightly lower than the meta-analytic estimate by Roberts and DelVecchio (2000) for the same age range. The moderate stability of personality indicates substantial rank-order change, which enables environmental factors, such as social relationship quality, to influence personality development. As we expected, quality of social relationships was found to be considerably less stable than personality characteristics. These results are consistent with previous findings of Asendorpf and van Aken (2003) and Neyer and Asendorpf (2001).

We included self-esteem as a surface characteristic of personality, following a categorization proposed by Asendorpf and van Aken (2003). Unexpectedly, the rank-order stability correlation of self-esteem reached a level comparable to those of the other core personality traits ($r = .39$). Using the same sample of the present study, Asendorpf and van Aken (2003) found only a relatively small rank-order stability correlation ($r = .18$) of self-esteem from the age of 12 years to the age of 17 years. The increase stability of self-esteem after adolescence may be due to the fact that maturational changes are reduced during the transition into adulthood, bringing environmental changes under increasing individual control and allowing for a more stable sense of self. Given the trait-like level of stability of self-esteem at later ages, its status as a surface personality trait may

only apply to younger age groups, though more research is needed to settle this issue empirically.

After the stability of personality and quality of social relationship, we investigated the mechanisms that may underlie the changes in personality during emerging adulthood. In our study, we tested two main approaches on personality development: The Five-Factor Theory, which stresses the endogenous character of personality development and does not allow for any environmental influences (McCrae & Costa, 1999; McCrae et al., 2000), and the dynamic interactionism paradigm, which posits a more contextualistic perspective taking into account both endogenous and environmental factors in personality development (Caspi & Roberts, 1999; Magnusson, 1999).

FFT predicts significant paths from personality to change in social relationship quality, whereas it does not predict social relationship quality to have an impact on personality change. Contrary to our expectation, however, personality did not predict changes in relationship quality. Because the current study presents a confirmatory test of hypotheses derived from competing models, we regard the lack of significant results deriving from this model as noteworthy information. By comparison, we found that social relationship quality predicted changes in personality. Specifically, conflict with father at the age of 17 years was related to decreases in emotional stability, conscientiousness and self-esteem 6 years later. In addition, conflict with mother at the age of 17 years was related to decreases in emotional stability and self-esteem, and conflict with best friend was related to decreases in extraversion and self-esteem. The only positive effect was found for perceived support from best friend, which was positively associated with changes in extraversion. Change in self-esteem was the outcome that was affected the most by conflict with parents and best friend. These results suggest that, during emerging adulthood, personality is influenced by relationship quality, with a predominant influence exerted by conflict.

Overall, the picture emerging from our findings does not provide support for a strict endogenous perspective of personality development. However, given the lack of personality influence on social relationship quality, it is also not possible to completely embrace the *dynamic interactionism* paradigm. Although the contextualistic approach predicts the effect of environment on personality, it also predicts effects of personality on environment, which we did not find in the current study. Thus, our study might be more in support of an environmental mechanism of personality change, rather than a person-environment transactional mechanism. Nevertheless, these findings draw attention to the substantial impact of relationships quality and experiences in influencing personality change throughout late adolescence and young adulthood (Neyer & Lehnart, 2007).

One possible explanation of the predominant effect of environment on personality may be the effect of identity consolidation on the transaction between environmental factors and personality development. A clear sense of identity achievement or consolidation has been described as a

“potential filter of the information and life experiences” that affects personality development (Roberts & Del Vecchio, 2000). During emerging adulthood it is likely that individuals have not reached the complete achievement of a consolidated identity, therefore the filtering process may not work properly, allowing environmental factor to exert a large influence on personality. Pals (1999) claimed that the process of identity consolidation may be an important mechanism of personality change during emerging adulthood, capturing the subjective experiences of the transition into new adult roles. In Western societies, more and more individuals appear to experience a period of prolonged adolescence, causing them to postpone their commitment to adult roles. Accordingly, Arnett characterized emerging adulthood as a period in which the exploration of roles and the search for a stable and viable identity is a broader phenomenon than the commitment to those roles (Arnett, 2002).

A final perspective on personality-relationship associations is the *parallel continuities hypothesis*, which states that individual behavior will be more stable when there is concurrent stability in the environment, in particular within the parenting or family system (Caspi, 1993; Halverson & Wampler, 1997; Moss & Susman, 1980). In this study we found a few significant correlated changes in personality and social relationship quality, though not enough to completely support the parallel continuity hypothesis. In previous studies significant concomitant changes have been found between personality and life goals (B.W. Roberts, O'Donnell, & Robins, 2004). The difference between the present study and the study of Roberts et al. (2004) may be that life goals are more intrapsychic features, while social relationship quality depends on both intrapsychic evaluation of the relation and the actual quality of it. Goals can be seen as causal outcomes of disposition, thus, as a direct expression of individual traits, and it is therefore more likely they change in correlation with change in personality.

In the present study, relationship conflict influenced personality in a direction opposite to the normative developmental pattern found by previous studies on mean-level changes (Helson, Kwan, John, & Jones, 2002; McCrae et al., 2000; McGue et al., 1993; B.W. Roberts, Caspi, & Moffitt, 2001; Robins et al., 2001; Srivastava et al., 2003). Rather, relationship conflict exerted a negative influence on changes in self-esteem, emotional stability and conscientiousness. It seems that having conflicts with parents and friends may slow down the normative process of development toward a mature and more stable personality. Previous studies discovered that the perception of parental qualities, and of parent-child relationship quality, are generally related to psychological well-being (existential well-being, life satisfaction and self-esteem), problem behavior (substance use and delinquency), and school adjustment (Shek, 2002). The relevant effect of conflict on personality is important in the light of previous research focusing mainly on the positive aspects of social relationship quality, such as

support (Branje, van Lieshout, & van Aken, 2004, 2005). Future research should take into account both support and conflict in order to have a comprehensive picture of social relationship quality in transaction with other factors.

The present study has some limitations. Even though we could assuage concerns regarding possible artefacts caused by heterotypic measures for the majority of the Big Five scales, openness/culture's corrected correlation shows that the two instruments are not equivalent regarding this particular scale. This may be the reason for the low stability of the fifth factor of personality and for the lack of results for the associations including openness/culture. In addition, the use of heterotypic measures did not allow the investigation of mean-level stability, which could have provided a more comprehensive picture of personality development. Another limitation is that the study consisted of only two assessments, and the time span covered was relatively small. Studies with multiple assessments may help in assessing changes in a more reliable way, offering the chance to find significant effects of personality on social relationship quality, and vice versa. Such designs could also clarify whether the effect on personality change is only a short-term effect or endures even when the original environmental influence has disappeared. Likewise, such studies are necessary to disentangle nonlinear growth trajectories of the development of personality. Although the goal of the present study was at best achieved with a simple, parsimonious model that includes only the variables we were interested in, in future studies the inclusion of other variables may help discovering moderators of the association between personality and social relationship quality. A final limitation of the study is the use of self-report for personality and social relationship quality data.

References

- Arnett, J.J. (2000). Emerging adulthood: A theory of development from the late teens through the twenties. *American Psychology*, 55, 469 – 480.
- Arnett, J.J. (2002). The psychology of globalization. *American Psychologist*, 57, 774–783.
- Arnett, J.J. (2004). *Emerging adulthood: The winding road from the late teens through the twenties*. New York: Oxford University Press.
- Asendorpf, J.B., & van Aken, M.A.G. (2003). Personality-relationship transaction in adolescence: Core versus surface personality characteristics. *Journal of Personality*, 71, 629–666.
- Asendorpf, J.B., & Wilpers, S. (1998). Personality effects on social relationships. *Journal of Personality and Social Psychology*, 74, 1531–1544.
- Borkenau, P., & Ostendorf, F. (1993). *Neo-Fünf-Faktoren-Inventar nach Costa und McCrae* [NEO-Five-Factor Inventory after Costa and McCrae]. Göttingen: Hogrefe.
- Branje, S.J.T., van Lieshout, C.F.M., & van Aken, M.A.G. (2004). Relations between big five personality characteristics and per-

- ceived support in adolescents' families. *Journal of Personality and Social Psychology*, 86, 615–628.
- Branje, S.J.T., van Lieshout, C.F.M., & van Aken, M.A.G. (2005). Relations between agreeableness and perceived support in family relationship: Why nice people are not always supportive. *International Journal of Behavioral Development*, 29, 120–128.
- Caspi, A. (1993). Why maladaptive behaviors persist: Sources of continuity and change across the life course. In D.C. Funder, & R.D. Parke (Eds.), *Studying lives through time: Personality and development* (pp. 343–376). Washington, DC: American Psychological Association.
- Caspi, A. (1998). Personality development across the life course. In W. Damon, & N. Eisenberg (Eds.), *Handbook of child psychology: Social, emotional and personality development* (Vol. 3, pp. 311–388). New York: Wiley.
- Caspi, A., & Bem, D.J. (1990). Personality continuity and change across the life course. In L. Pervin (Ed.), *Handbook of personality theory and research* (pp. 549–575). New York: Guilford.
- Caspi, A., & Roberts, B.W. (1999). Personality continuity and change across the life course. In L. Pervin, & O.P. John (Eds.), *Handbook of personality psychology: Theory and research* (2nd ed., pp. 300–326). New York: Guilford.
- Côté, J.E. (1996). Sociological perspectives on identity formation: The culture-identity link and identity capital. *Journal of Adolescence*, 19, 417–428.
- Furman, W., & Buhrmeister, D. (1985). Children's perceptions of the personal relationships in their social networks. *Developmental Psychology*, 21, 1016–1024.
- Halverson, C.F., & Wampler, K.S. (1997). Family influences on personality development. In J. Hogan, J.A. Johnson, & S.R. Briggs (Eds.), *Handbook of personality psychology* (pp. 241–267). San Diego, CA: Academic Press.
- Hartup, W.W., & Laursen, B. (1999). Relationships as developmental contexts: Retrospective themes and contemporary issues. In W.A. Collins, & B. Laursen (Eds.), *Relationships as developmental contexts: The minnesota symposia on child psychology* (Vol. 30, pp. 13–35). Mahwah, NJ: Erlbaum.
- Helsen, M., Vollebergh, W., & Meeus, W. (2000). Social support from parents and friends and emotional problems in adolescence. *Journal of Youth and Adolescence*, 29, 319–335.
- Helson, R., Kwan, V.S.Y., John, O.P., & Jones, C. (2002). The growing evidence for personality change in adulthood: Findings from research with personality inventories. *Journal of Research in Personality*, 36, 287–306.
- Hogan, R., & Roberts, B.W. (2004). A socioanalytic model of maturity. *Journal of Career Assessment*, 12, 207–217.
- Loehlin, J.C. (1992). *Genes and environment in personality development*. Newbury Park, CA: Sage.
- McCrae, R.R., & Costa, P.T., Jr. (1999). A five-factor theory of personality. In L. Pervin, & O.P. John (Eds.), *Handbook of personality: Theory and research* (pp. 139–153). New York: Guilford.
- McCrae, R.R., Costa, P.T., Jr., Ostendorf, F., Angleitner, A., Hřebíčková, M., Avia, M.D. et al. (2000). Nature over nurture: Temperament, personality, and life span development. *Journal of Personality and Social Psychology*, 78, 173–186.
- McGue, M., Bacon, S., & Lykken, D.T. (1993). Personality stability and change in early adulthood: A behavioral genetic analysis. *Developmental Psychology*, 29, 96–109.
- Magnusson, D. (1990). Personality development from an interactional perspective. In L. Pervin (Ed.), *Handbook of personality: Theory and research* (pp. 193–220). New York: Guilford.
- Magnusson, D. (1999). Holistic interactionism: A perspective for research on personality development. In L. Pervin, & O.P. John (Eds.), *Handbook of personality: Theory and research* (pp. 219–247). New York: Guilford.
- Marsh, H.W., & O'Neill, R. (1984). Self description questionnaire iii: The construct validity of multidimensional self-concept ratings by adolescents. *Journal of Education Measurement*, 21, 153–174.
- Mischel, W. (1968). *Personality and assessment*. Mahwah, NJ: Erlbaum.
- Morizot, J., & Le Blanc, M. (2003). Continuity and change in personality traits from adolescence to midlife: A 25-year longitudinal study comparing representative and adjudicated men. *Journal of Personality*, 71, 705–755.
- Moss, H.A., & Susman, E.J. (1980). Longitudinal study of personality development. In O.G. Brim, & J. Kagan (Eds.), *Constancy and change in human development* (pp. 530–595). Cambridge: Harvard University Press.
- Neyer, F.J., & Asendorpf, J.B. (2001). Personality-relationship transaction in young adulthood. *Journal of Personality and Social Psychology*, 81, 1190–1204.
- Neyer, F.J., & Lehnart, J. (2007). Relationships matter in personality development: Evidence from an 8-year longitudinal study across young adulthood. *Journal of Personality*, 75, 535–568.
- Ostendorf, F. (1990). *Sprache und Persönlichkeitsstruktur: Zur Validität des Fünf-Faktoren-Modells der Persönlichkeit* [Language and personality structure: Validity of the five-factor model of personality]. Regensburg, Germany: S. Roderer.
- Pals, J.L. (1999). Identity consolidation in early adulthood: Relations with ego-resiliency, the context of marriage, and personality change. *Journal of Personality*, 67, 295–329.
- Roberts, B.W., Caspi, A., & Moffitt, T.E. (2001). The kids are alright: Growth and stability in personality development from adolescence to adulthood. *Journal of Personality and Social Psychology*, 81, 670–683.
- Roberts, B.W., & Del Vecchio, W.F. (2000). The rank-order consistency of personality traits from childhood to old age: A quantitative review of longitudinal studies. *Psychological Bulletin*, 126, 3–25.
- Roberts, B.W., O'Donnell, M., & Robins, R.W. (2004). Goal and personality trait development in emerging adulthood. *Journal of Personality & Social Psychology*, 87, 541–550.
- Roberts, B.W., Walton, K.E., & Viechtbauer, W. (2006a). Patterns of mean-level change in personality traits across the life course: A meta-analysis of longitudinal studies. *Psychological Bulletin*, 132, 1–25.
- Roberts, B.W., Walton, K.E., & Viechtbauer, W. (2006b). Personality trait change in adulthood: Reply to Costa and McCrae. *Psychological Bulletin*, 132, 29–32.
- Roberts, B.W., Wood, D., & Smith, J.L. (2005). Evaluating five factor theory and social investment perspectives on personality trait development. *Journal of Research in Personality*, 39, 166–184.
- Roberts, R.E.L., & Bengtson, V.L. (1993). Relationships with parents, self-esteem, and psychological well-being in young adulthood. *Social Psychology Quarterly*, 56, 263–277.
- Robins, R.W., Caspi, A., & Moffitt, T.E. (2002). It's not just who you're with, it's who you are: Personality and relationship ex-

- periences across multiple relationships. *Journal of Personality*, 70, 925–964.
- Robins, R.W., Fraley, R.C., Roberts, B.W., & Trzesniewski, K.H. (2001). A longitudinal study of personality change in young adulthood. *Journal of Personality*, 69, 617–640.
- Rubin, K.H., Bukowski, W., & Parker, J.G. (1998). Peer interactions, relationships, and groups. In W. Damon, & N. Eisenberg (Eds.), *Handbook of child psychology* (Vol. 3, pp. 619–700). New York: Wiley.
- Shek, D.T.L. (2002). The relation of parental qualities to psychological well-being, school adjustment, and problem behavior in chinese adolescents with economic disadvantage. *American Journal of Family Therapy*, 30, 215–230.
- Shiner, R.L., Masten, A.S., & Tellegen, A. (2002). A developmental perspective on personality in emerging adulthood: Childhood antecedents and concurrent adaptation. *Journal of Personality and Social Psychology*, 83, 1165–1177.
- Srivastava, S., John, O.P., Gosling, S.D., & Potter, J. (2003). Development of personality in early and middle adulthood: Set like plaster or persistent change? *Journal of Personality & Social Psychology*, 84, 1041–1053.
- Steiger, J.H. (1980). Tests for comparing elements of a correlation matrix. *Psychological Bulletin*, 87, 245–251.
- Stein, J.A., Newcomb, M.D., & Bentler, P.M. (1986). Stability and change in personality: A longitudinal study from early adolescence to young adulthood. *Journal of Research in Personality*, 20, 276–291.
- Terracciano, A., McCrae, R.R., Brant, L.J., & Costa, P.T., Jr. (2005). Hierarchical linear modeling analyses of the NEO-PI-R scale in the Baltimore longitudinal study of aging. *Psychology and Aging*, 20, 493–506.
- Weinert, F.E., & Schneider, W. (1999). *Individual development from 3 to 12: Findings from the munich longitudinal study*. Cambridge, UK: Cambridge University Press.

About the authors

Cristina Sturaro is currently working as Junior Researcher at the Clinical Psychology and Developmental Psychology Department of the VU University of Amsterdam. Her main interests cover the development of behavioral and emotional problems during childhood, and its association with peer social relationships.

Jaap Denissen is currently Junior Professor of Personality Development at Humboldt University of Berlin. His research interests focus on the interplay between personality and social relationships in the evolutionary and ontogenetic development of personality, using a lifespan perspective.

Marcel van Aken is Professor in the Department of Developmental Psychology at Utrecht University. His research interests focus on the interplay between individual characteristics and environmental factors in the development of (problem) behavior.

Jens B. Asendorpf is Professor of Personality Psychology at the Humboldt-University of Berlin. His research interests include personality development and assessment, evolutionary psychology, and the development of social and romantic relationships.

Jaap Denissen

Humboldt University of Berlin
 Unter den Linden 6
 D-10099 Berlin
 Germany
 Tel. +49 30 2093-9439
 Fax +49 30 2093-9431
 E-mail jaap.denissen@staff.hu-berlin.de